

# OZONE-IN-WATER SENSOR BMT 964 AQ

*High Concentration  
Ozone-in-Water Sensor*

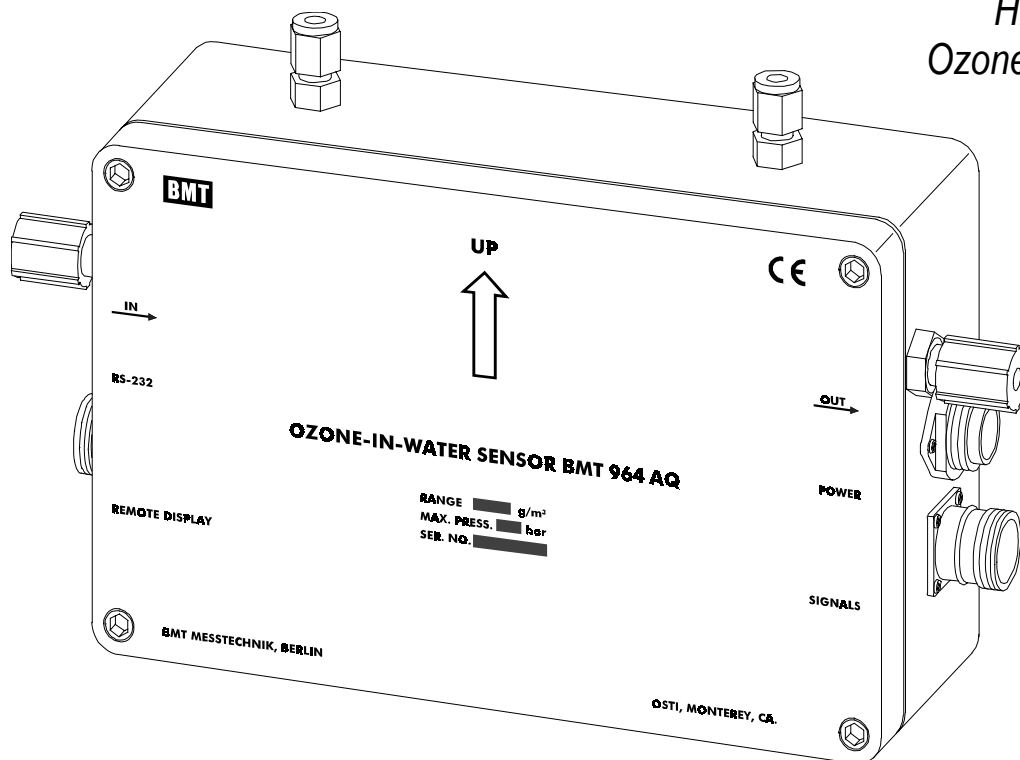

## FEATURES

- Dual beam UV photometer
- Melted quartz cuvette
- Warranty 3 years
- Long-life mercury lamp
- High accuracy, error less than 0.5%
- Ranges from 10 to 150 g/m<sup>3</sup> (ppm)
- HF resistant version available (50g/m<sup>3</sup>)
- Relay contact for control of automatic zeroing
- Failure warnings include: lamp low, cuvette dirty, overrange, summary error
- Key functions programmable via the front panel, or a Windows PC
- Display in g/m<sup>3</sup> or ppm
- High and low limit alarms
- Timing sequence for automatic zeroing
- 4-20mA and 0-10V isolated outputs
- RS-232 interface (bidirectional)
- Option: Remote Display for readout and control

## APPLICATIONS

- Monitoring of ozone in ultra pure water
- Semiconductor ozone processes

The OZONE-IN-WATER SENSOR BMT 964 AQ is a UV photometer for the direct measurement of the ozone content of ultra pure, de-ionised water. A special version BMT 964 AQ/HF for up to 5% hydrofluoric acid, range 50 ppm, is available. The instrument is based upon our OZONE ANALYZER BMT 964 for gaseous ozone (see data sheet of standard BMT 964).

The BMT 964 AQ is a SENSOR because it does not have a display. It is designed to directly be connected to a workstation via a 4 - 20 mA, or 0 - 10 V, signal line.

An optional Remote Display BMT 964 RD is available for installations without a workstation. To operate with the Remote Display, the BMT 964 AQ has to be ordered in the version BMT 964 AQ/RD.

Superior stability of the photometer is achieved by use of a true dual beam optical system with an extremely long-life mercury lamp. MTBF of the instrument, including the lamp, is in excess of 65,000 hours. Excluding the lamp it is 120,000 hours.

The built-in microcontroller allows for programming many parameters of the instrument via the Remote Display, or via a Windows PC using the software BMT 964 Link (delivered with the instrument).

## SPECIFICATIONS

measurement principle	dual-beam UV photometer (254 nm), no moving parts
MTBF	instrument incl. UV lamp 65,000 h, excl. UV lamp 120,000 h
UV lamp	low pressure mercury lamp, long life design, burnt-in for 300 h
display	16 character alphanumeric backlit LCD
concentration ranges	10, 50, 100, 150 g/m <sup>3</sup> , selectable units g/m <sup>3</sup> and ppm
concentration error	0.5 % max.
repeatability error	0.2 % max.
response time	0.03 s (analog output), 0.3 s (display)
zero drift	0.2 % per day, after 10 minutes warm-up, non-cumulative
proof pressure	10 g/m <sup>3</sup> : 1.0 barg 50/100 g/m <sup>3</sup> : 4.0 barg 150 g/m <sup>3</sup> : 6.0 barg 50 g/m <sup>3</sup> HF: 2.5 barg
ambient temperature	0 - 50°C (non-condensing)
materials in contact with ozone	quartz (cuvette), PFA (tubing, fittings)
fluid ports	1/4" Flaretek
recommended flow rate	0.1 to 0.3 l/min typical
pressure drop	approx. 33 mbar at 0.3 l/min
signal outputs	concentration 4 - 20 mA (isolated, active) concentration 0 - 10 V (isolated)
concentration alarms	High Alarm, Low Alarm, latching, not latching
control input	set to zero (24 V, 18 mA, isolated)
control outputs	relay contacts, 28 V, 0.5 A, isolated: Lamp Low Cuvette Dirty High Alarm Low Alarm Purge Control
error handling	Error Relay: 30 V, 1 A, summarizing instrument failures.  Warnings and errors: Lamp Low Warning, Lamp Low Error, Lamp Off Error, Cuvette Dirty Warning, Cuvette Dirty Error, Overrange, Overpressure
serial interface	RS-232, bidirectional, 2400 - 38400 Baud
automatic zeroing	possible via the purge contact
software	BMT 964 Link, instrument configuration and readout of Event and Error Logs on a Windows PC
power	wide range input: 85 - 264 VAC, 15 VA optional: 12 - 36 VDC, 15 W
dimensions (W x H x D)	260 x 160 x 82 (W x H x D)
weight	3 kg

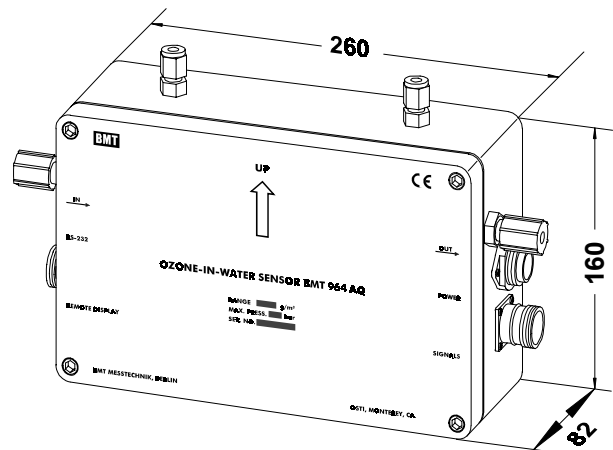

dimensional outline

The OZONE - IN - WATER SENSOR BMT 964 AQ comes in a splash proof aluminium enclosure (IP 65, NEMA 4X) 260 x 160 x 82 mm (W x H x D) with sea water resistant coating (RAL 5009, azure), and weighs about 3 kg. Four mounting brackets are provided for installing the SENSOR where it is needed, e.g. underneath a work bench. All electric connectors are water proof.

When the fluid to be measured is at lower temperature than the ambient, flushing of the instrument with clean dry air (or nitrogen) is necessary to prevent condensation of water. Flow rate of the dry gas should be about 0.2 l/min.

If a throttle (flow resistance) is installed to control the flow rate through the OZONE-IN-WATER SENSOR, this throttle must be positioned behind the sensor (never in front of it!), because gas could bubble out after a pressure drop disturbing measurement.

As long as the cuvette of the SENSOR remains clean, zeroing of the instrument is not necessary for weeks, or even for months. But for safety, zero reading should be checked on a regular basis.

A Remote Display is available as an option for monitoring the measured ozone concentration and for manual control.

In the OZONE-IN-WATER SENSOR BMT 964 AQ the isolated signal outputs are tied to Protective Ground by a resistor of 10 MegOhms.

Additional BMT Products (for details, refer to the appropriate data sheets):

- BMT 964 AQ-INLINE with 3/4" Flaretek fittings
- BMT 964 (standard version) for ozone measurement in the gas phase
- BMT 930 Ozone Monitor for TLV monitoring in ambient air (1, 3 & 6 channels)
- BMT 802X (4 g/h) and BMT 803 (8 g/h) Ozone Generators
- Broad spectrum of field-proven Accessories for ozone measurement

Rev. Jun 02