

OZONE ANALYZER BMT 964 BT

*Bench Top Version of
High Concentration
Ozone Gas Analyzer*

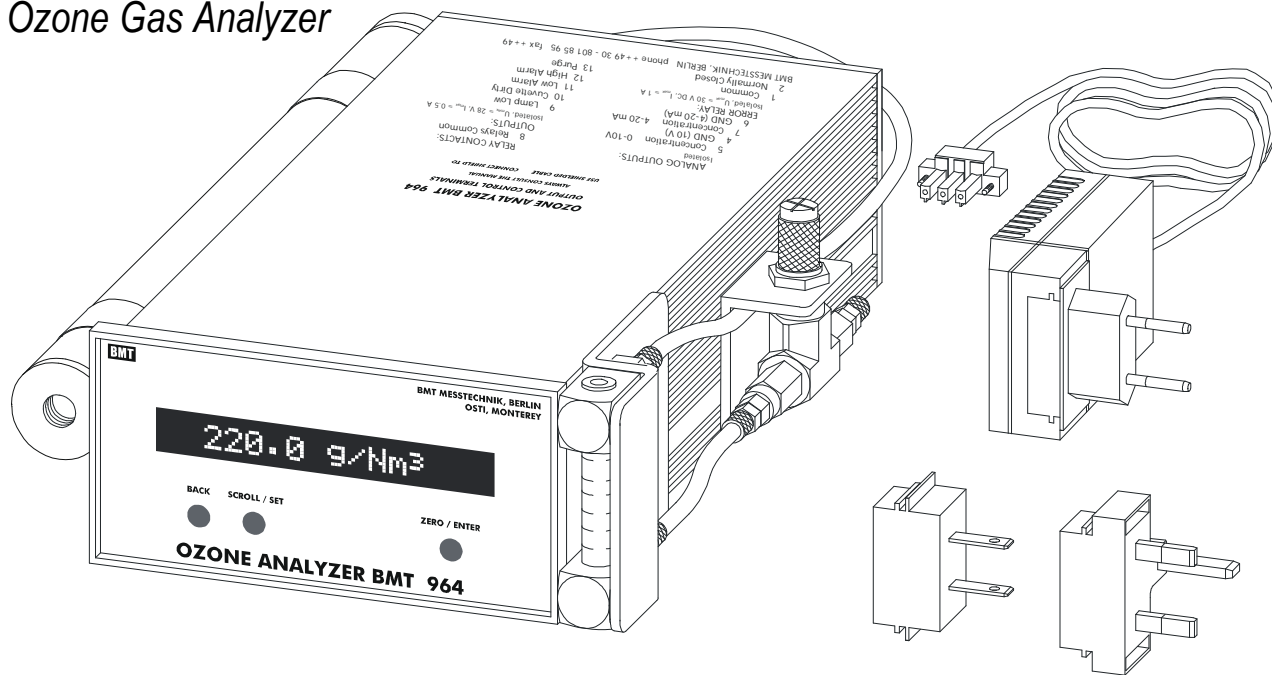

FEATURES

- Dual beam UV photometer
- Warranty 3 years
- Long-life mercury lamp
- High accuracy, error less than 0.5%
- Pressure and temperature compensated
- Ranges from 2 to 400 g/Nm³
- Built-in sample gas filter
- Built-in purge unit as an option
- Relay contact for control of automatic zeroing
- Failure warnings include: lamp low, cuvette dirty, overrange, summary error
- Key functions programmable via the front panel, or a Windows PC
- Display in g/Nm³, %wt/wt, or ppm_v
- High and low limit alarms
- Timing sequence for automatic zeroing
- Pressure readout in bar, psi, Torr or MPa
- 4-20mA and 0-10V isolated outputs
- RS-232 interface (bidirectional)

APPLICATIONS

- Ozone measurement on the bench
- Ozone measurement in the laboratory
- Ozone measurement in the field
- Experiments with ozone
- Waste water treatment
- Industrial ozone processes

The OZONE ANALYZER BMT 964 BT is the portable version of the standard BMT 964 (see data sheet of standard BMT 964). The instrument is not much bigger than the standard BMT 964. For safety reasons it has a wall mount wide-range power supply 24 VDC.

The BMT 964 BT has a throttle valve with flow meter attached on the right (sample gas inlet), and a Catalyzing Cartridge (catalytic ozone destruct) on the left to remove the ozone from the sample gas before it is vented to the ambient. The sample gas enters the throttle valve through a fitting for 3 x 5 mm (1/8" x 3/16") PTFE tubing, and then enters the BMT 964 BT through a replaceable glass felt sample gas filter. Upon exiting the BMT 964 BT, the sample gas passes through the Catalyzing Cartridge where the ozone is destroyed.

As an option the BMT 964 BT can be ordered with a built-in purge unit (3-way solenoid valve plus air pump) for fully automatic purging and zeroing the analyser. Another option is a soft carrying case.

SPECIFICATIONS

measurement principle	dual-beam UV photometer (254 nm),
MTBF	instrument incl. UV lamp 65,000 h, excl. UV lamp 120,000 h
UV lamp	low pressure mercury lamp, long life design, burnt-in for 300 h
display	16 character alphanumeric backlit LCD
concentration ranges	50, 100, 200, 300, 400 g/Nm ³ , selectable units g/Nm ³ , %wt/wt and ppm _v
optional ranges	2, 5, 10, 20 g/Nm ³ , selectable units g/Nm ³ , %wt/wt and ppm _v
concentration error	0.5 % max.
repeatability error	0.2 % max.
response time	0.03 s (analog output), 0.3 s (display)
zero drift	0.2 % per day, after 10 minutes warm-up, non-cumulative
proof pressure	min. 1 bar above pressure range
ambient temperature	0 - 50°C (non-condensing)
materials in contact with ozone	quartz (cuvette windows), Al ₂ O ₃ (cuvette), FFPM (window seals), PTFE (tubing), stainless steel (fittings, cuvette spacer)
gas ports	for PTFE tubing 3x5 mm (1/8" x 3/16"), opt. 4x6 mm PTFE Built-in sample gas filter is standard
recommended flow rate	0.1 to 1 l/min typical
temperature compens.	is standard
pressure compensation	with built-in cuvette pressure transducer, for ozone measurement at an arbitrary systemic pressure, abs. pressure range 1.15 bar (optional up to 4.0 bar in steps of 0.5, please specify) units selectable: bar, psi, Torr, MPa
signal outputs	concentration 4 - 20 mA (isolated, active) concentration 0 - 10 V (isolated)
concentration alarms	High Alarm, Low Alarm, latching, not lat.
control input	set to zero (24 V, 18 mA, isolated)
control outputs	relay contacts, 28 V, 0.5 A, isolated: Lamp Low Cuvette Dirty High Alarm Low Alarm Purge Control
error handling	Error Relay: 30 V, 1 A, summarizing instrument failures Warnings and errors: Lamp Low Warning, Lamp Low Error, Lamp Off Error, Cuvette Dirty Warning, Cuvette Dirty Error, Overrange, Overpressure
serial interface	RS-232, bidirectional, 2400 - 38400 Baud
automatic zeroing	with opt. external or internal purge pump and solenoid valve (e.g. BMT Purge Unit)
software	BMT 964 Link, instrument configuration and readout of Event and Error Logs on a Windows PC
power	wide range input: 85 - 264 VAC, 15 VA via wall mount power supply 24 VDC
dimensions (W x H x D)	144 x 72 x 230 mm, DIN 43 700
weight	2.1 kg

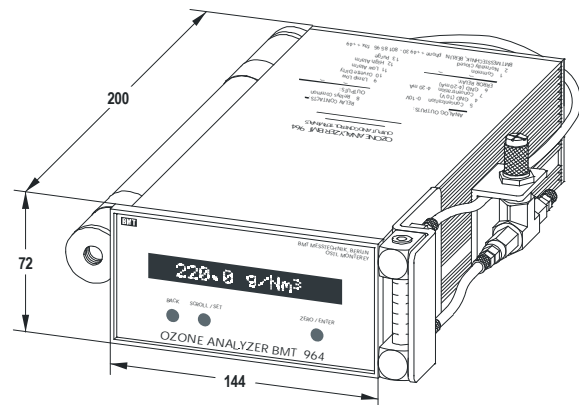

The OZONE ANALYZER BMT 964 BT is a portable instrument in an enclosure according to DIN 43 700.

Fittings for the inlet and outlet tubing (connected to the Catalyzing Cartridge), and the connectors for the signals, and RS-232 interface, are accessible from the rear. The total depth thus is about 250 mm.

As an option the OZONE ANALYZER BMT 964 BT may be ordered equipped with an Internal Purge Unit, which consists of a built-in 3-way solenoid valve plus air pump with particle filter, for fully automatic purging and zeroing the instrument. This option makes sure that the cuvette is flushed with ambient filtered air (zero gas) upon activating the AUTO ZERO function.

For applications in the field we recommend the soft carrying bag which has room enough for the BMT 964 BT and accessories.

Additional BMT Products (for details, refer to the appropriate data sheets):

- BMT 964 C (Cabinet) for truly automatic stand-alone applications in a rough service environment
- BMT 964 AQ and BMT 964 AQ-INLINE for ozone measurement in DI (de-ionized) water
- BMT 964 AQ/HF for ozone measurement in DI water with HF
- OZONE-IN-OFF-GAS System
- BMT 930 Ozone Monitor for TLV monitoring in ambient air (1, 3 & 6 channels)
- Ozone generators BMT 802X and BMT 803 for small scale ozone production from oxygen 4 to 8 g/h

Rev. Jan 07