

AMBIENT OZONE SIMULATOR AOS 1

*For comparison of
Ambient Ozone Monitors*

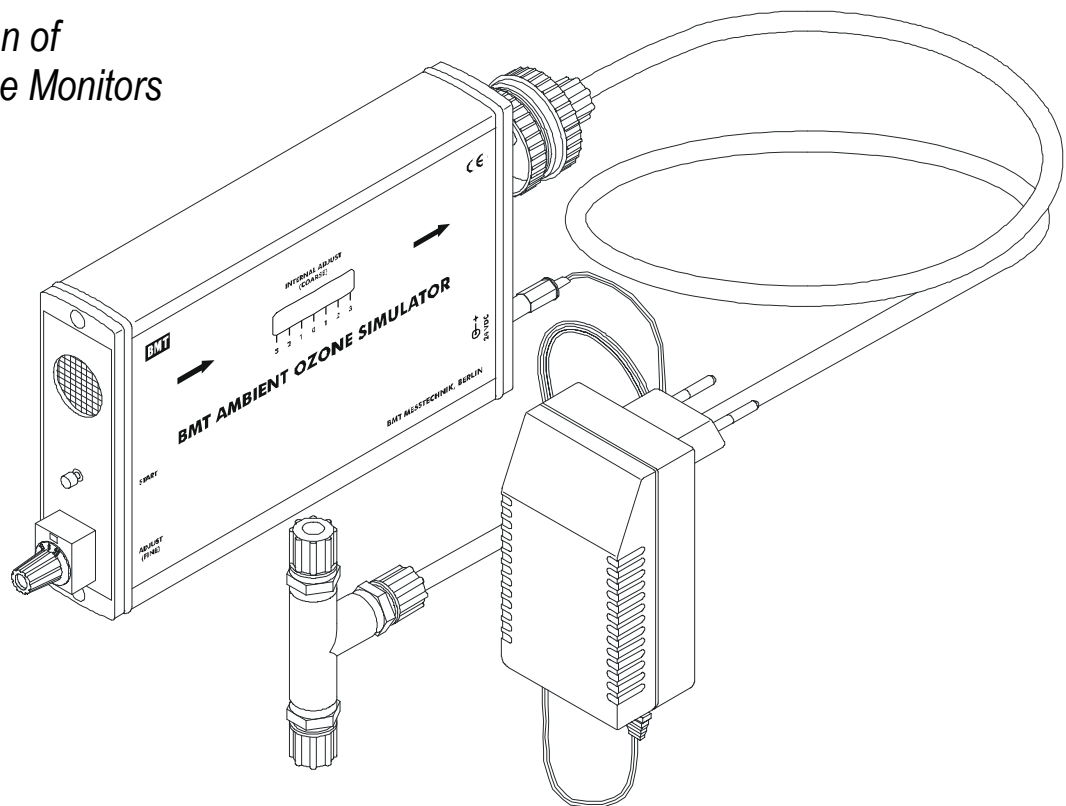

The BMT AMBIENT OZONE SIMULATOR AOS 1 is a simple means to comparing two ambient ozone monitors with each other.

The small box (approx. 17 x 11 x 3.3 cm) contains an ozone producing UV lamp, and the high voltage power supply. Via an air filter the sample air is sucked through this box by the two BMT ambient OZONE MONITORS which are connected to the outlet of the box via a tee.

Power (24 VDC, 300 mA) is supplied by a small wall-mount power adaptor. This wide range input power supply (100 - 240 VAC, 50/60 Hz) comes with three different exchangeable mains connectors for use in Europe, UK, USA, and Japan (Australia on request).

The output of the BMT AMBIENT OZONE SIMULATOR can be controlled in three different ways: 1) via an external 10 turns potentiometer "ADJUST (FINE)", 2) with an internal short plug to choose two electric power levels of the UV lamp, and 3) by two internal adjustable shutters shading the radiation emitting surface of the UV lamp.

BMT ambient OZONE MONITORS are operated at a constant sample air flow rate of 1 l/min, which is precisely electronically controlled. Performance of the BMT AMBIENT OZONE SIMULATOR AOS 1 thus is

defined at an air flow rate of 2 NI/min (1 NI/min for the reference monitor, and 1 NI/min for the device under test). The performance data given below have been evaluated with a constant (!) flow rate of 2 NI/min and at the ambient conditions 25°C, 1 atm, 50% RH.

With the internal short set to maximum power, the external fine adjust set to 100%, and the internal shutters fully open, the maximum ozone concentration is 1.5 ppmv. Without the internal short the maximum ozone concentration is 0.75 ppmv.

With the external fine adjust the concentration can be reduced nearly linearly from 100% down to approx. 2.7% (ratio 38:1). With the internal shutters the UV lamp can be shaded from maximum down to practically zero. This results in an extremely wide range of adjustment, to serve any ozone simulation needs.

When the BMT AMBIENT OZONE SIMULATOR AOS 1 is connected to the power line, the UV lamp starts automatically as long as the fine adjust is set to about 13% or higher. At a lower setting the lamp can be started with the push button "START".

In the instrument's front panel a small window is provided through which the UV lamp can be watched. This window has a radiation filter, of course, to remove any dangerous UV radiation.