

# AMBIENT OZONE SIMULATOR AOS 2

*For comparing two  
Ambient Ozone Monitors*



## FEATURES

- ozone source generating 40 - 1000 ppbv in air at 3 l/min
- built-in pump
- setting with 10-turn potentiometer
- UV lamp monitoring window
- two independent ozone ports
- ozone destruct for overflow
- ozone blower function
- particle filter at inlet port
- small, light weight, portable

## APPLICATIONS

- comparison of two ambient ozone monitors
- comparison of electro-chemical sensors with a reference monitor

The AMBIENT OZONE SIMULATOR AOS 2 is a simple and universal means for comparing two ambient ozone monitors (UV photometric) with each other, or comparing an ozone sensor (electro-chemical) with an ozone monitor as a reference.

The small box contains an ozone producing UV lamp, its high voltage power supply, and an air pump delivering more than three liters per minute of thoroughly filtered room air. Ambient ozone monitors usually are breathing one liter per minute or less. Thus the simulator AOS 2 delivers more ozonated air than necessary for two ozone monitors.

Power is supplied by a small wall-mount power adaptor. This wide range power supply comes with three different exchangeable connectors for use in Europe, UK, USA, and Japan.

With a 10-turn potentiometer the ozone content of the air leaving the AOS 2 can be set from about 40 to 1000 ppbv. This ozonated air is leaving the instrument via a manifold with two separate outlet fittings: one outlet for the device under test, and the other outlet for the reference ozone monitor. The overflow of ozonated air is leaving the manifold via an ozone destruct.

In the instrument's front panel a small window is provided through which the UV lamp can be watched. This window has a radiation filter to remove any dangerous radiation.

**SPECIFICATIONS**

feed gas	ambient air through particle filter
particle filter	replaceable insert, glass fiber felt
inlet flow rate	3 l/min (inlet)
sum of outlet flow rates	must be smaller than inlet flow rate
max. ozone concentration	> 1 ppm <sub>v</sub>
power setting	with 10-turn potentiometer
adjustment range	approx. 40 ppb <sub>v</sub> to more than 1000 ppb <sub>v</sub>
life expectancy of UV lamp	> 5 years at continuous operation
temperature	10 to 40°C
gas outlet port	for 4x6 mm or 5/32" x 1/4" FEP (PTFE)
power	12 VDC, 450mA wall mount adapter 100-240 VAC included
dimensions (WxHxD)	220 x 108 x 42 mm
weight	900 g

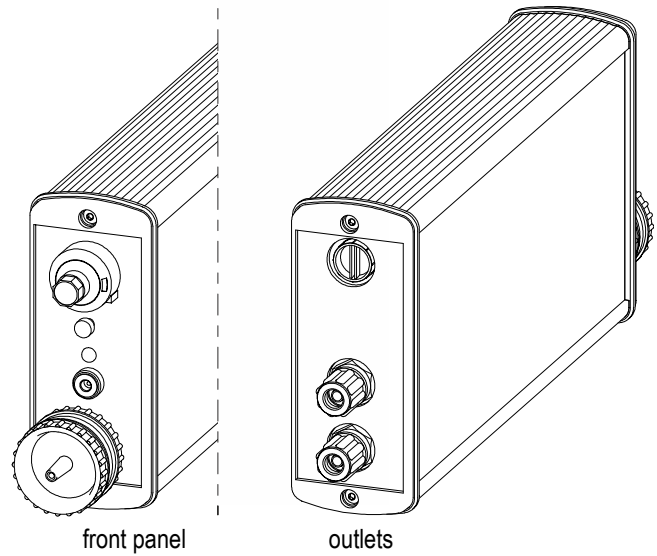

The following sketches illustrate possible uses of the AOS 2. In the normal configuration, *Out 2* would be connected to the DUT (Device Under Test) and *Out 1* to the precise UV photometric ozone monitor to be compared with (reference). The *Overflow* port has to be open so that the excess gas can leave the system through the catalyst:

Typical relation between potentiometer setting and output:

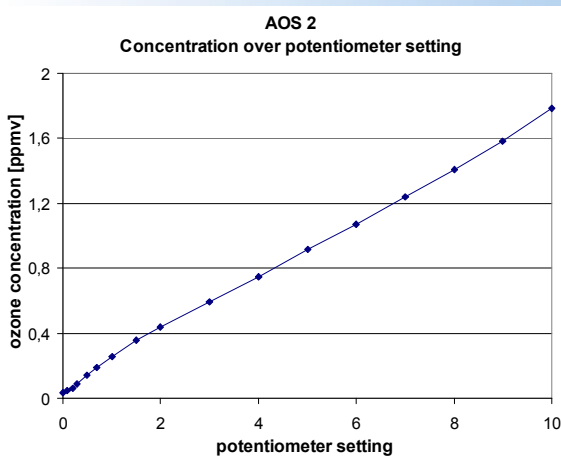

When the AOS 2 is connected to the power line, the UV lamp starts automatically as long as the fine adjust is set to about 10% or higher. At a lower setting the lamp can be manually started with the red push button "START".

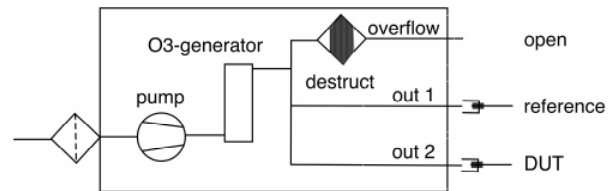

Alternatively, the overflow outlet can be closed. Now the AOS 2 becomes an ozone blower: the reference monitor is connected with one outlet whilst the other outlet is blowing out about two liters per minute of ozonated air, the ozone content of which is measured and indicated by the reference ozone monitor:

