

DIRT TRAP DT 50

For Dirt & Moisture Mitigation

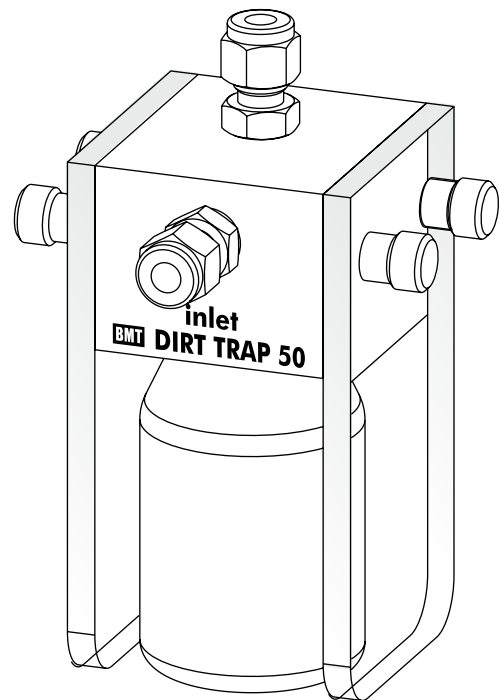

FEATURES

- Compact design
- Removable 50 ml glass vessel
- Fittings for 1/4" or 6 mm Swagelok
- Acrylic protection on two sides

APPLICATIONS

- Detecting presence of condensate and dirt
- For use with BMT 964/965 gas analysers

The DIRT TRAP DT 50 is an ozone-resistant washing bottle, which can be used when higher quantities of fluids may be expected to occasionally appear in the sample gas. The DT 50 may retain and store these fluids, and particulates, too.

For continues cooling and drying ozone sample gas, we recommend to use the sample gas dryer DH6.

Dimensions:

